

SECTION A-A

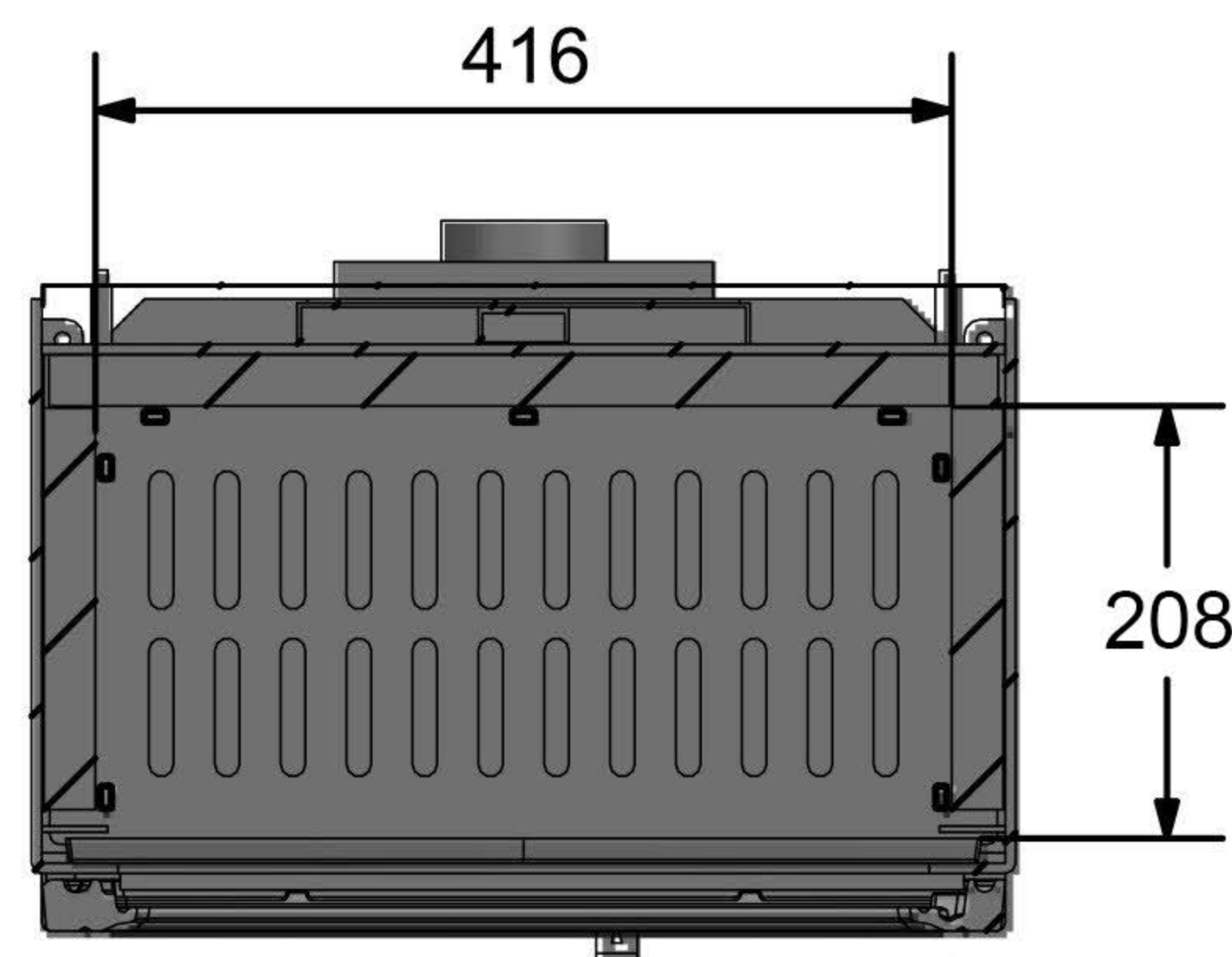

SECTION B-B

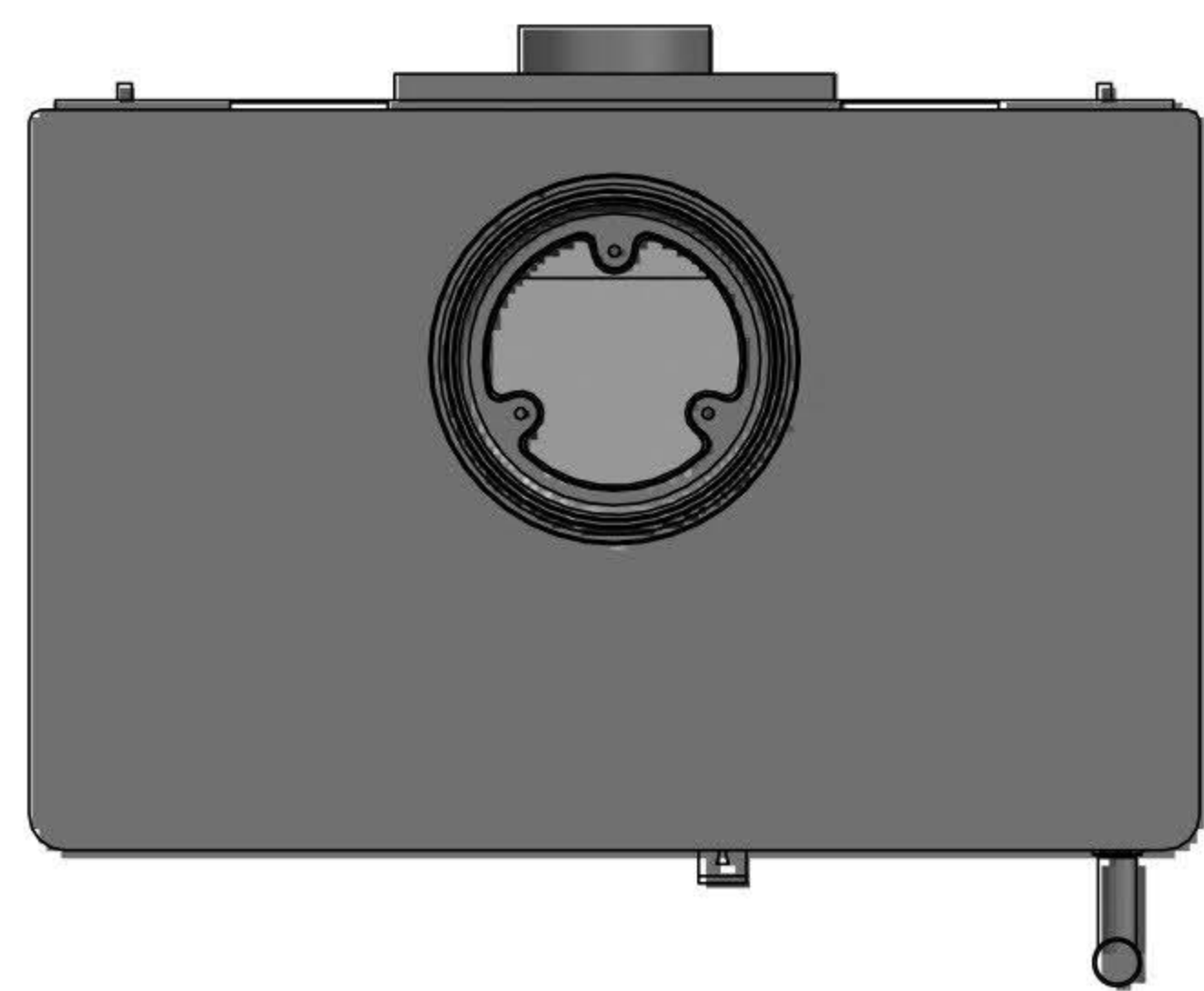
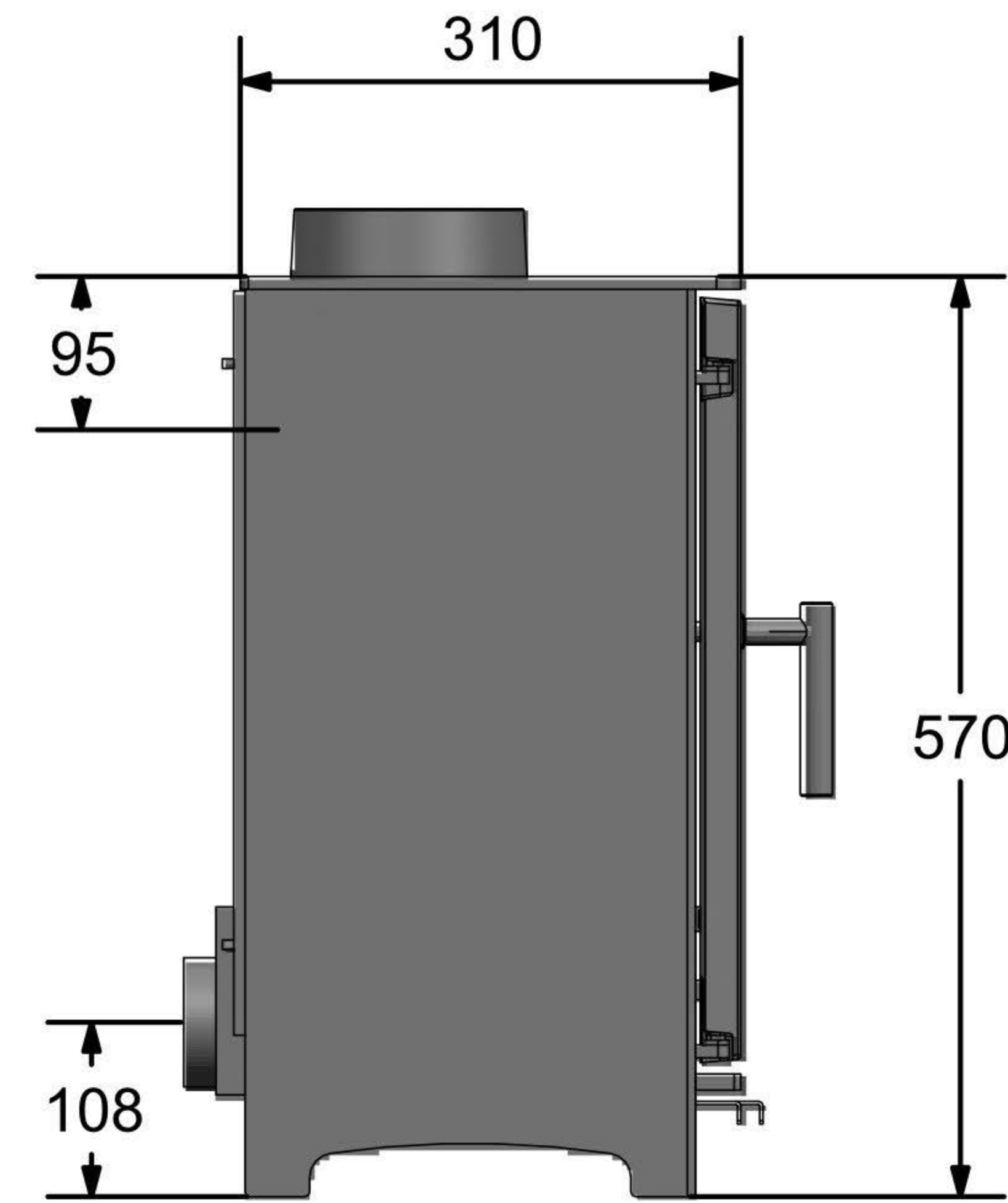
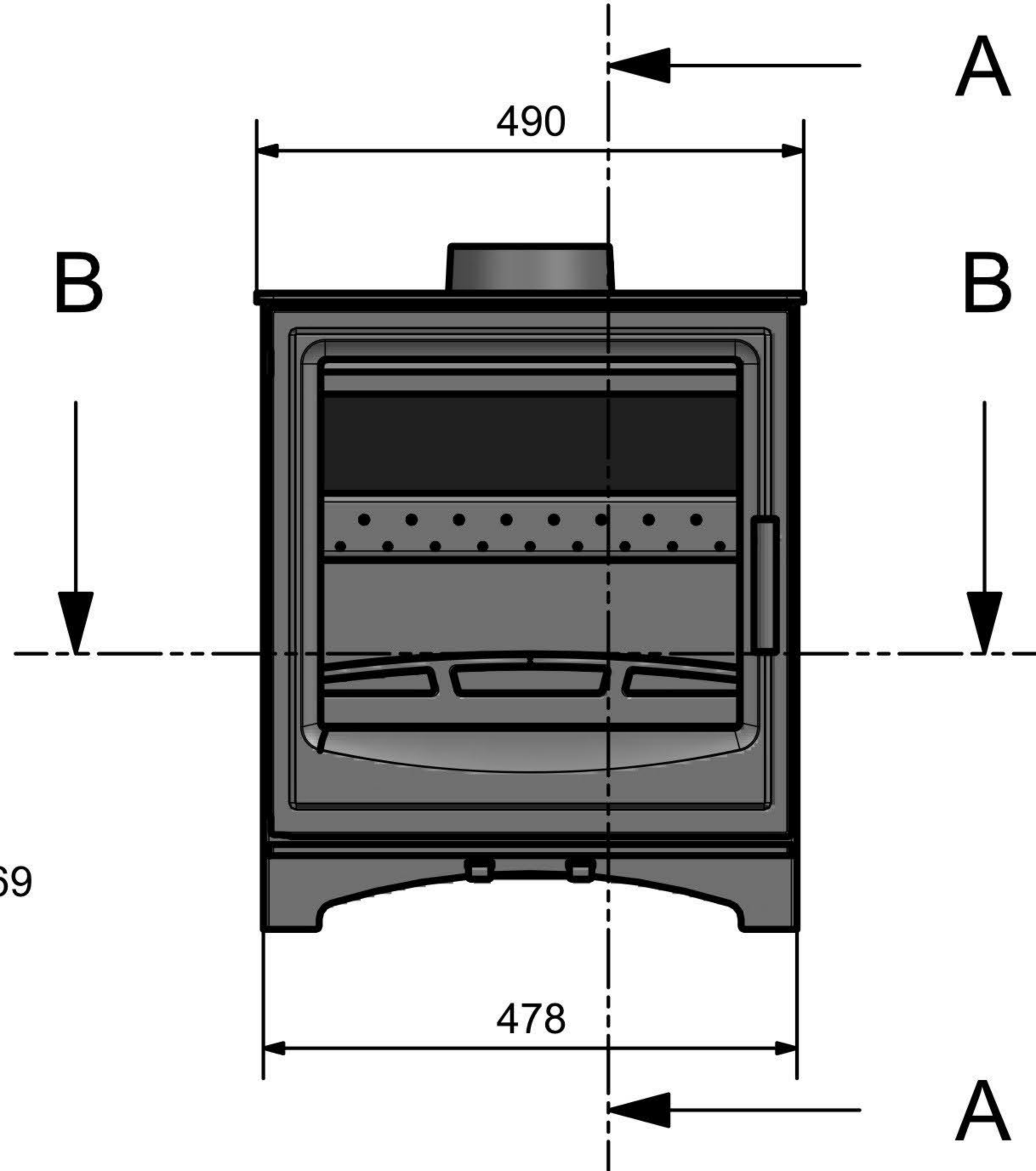
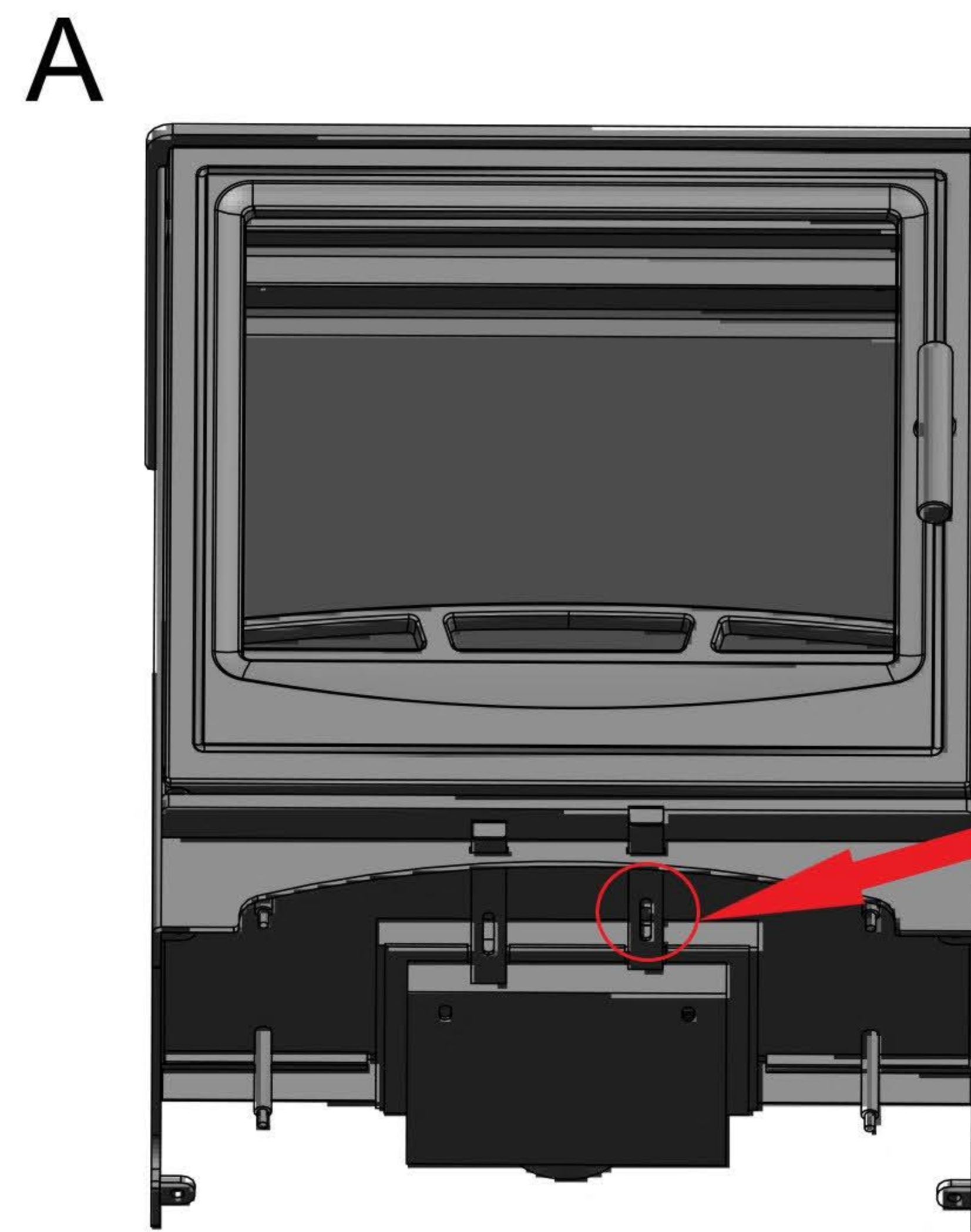

**We will use a screw here for preventing closeure of secondary air control beyond 7mm open**